

sicc
idee chiare
in cucina



2012
OVERVIEW



S



S I C C

SICC

è sinonimo di gusto, design, libertà compositiva; è il luogo in cui il saper fare incontra il saper comporre, generando soluzioni sempre nuove, dal forte spessore qualitativo e formale. La capacità di costruire un prodotto affidabile e duraturo, unita a una rete di distribuzione capillare e internazionale, hanno reso SICCC un punto di riferimento consolidato per il mercato mondiale delle cucine. Versatilità e stile la rendono partner sicura nella guida alla scelta della vostra prossima cucina.

SICC

stands for taste, design, freedom of composition; it is the place where know-how is teamed with composition design, leading to new and original solutions each time, marked by high quality and beguiling appeal. The ability to build a reliable and durable product, combined with a widespread international distribution network, have ranked SICCC as a consolidated point of reference for the world-wide kitchen market. Versatility and style make it the safest bet when you come to choose your next kitchen.

SICC

est un synonyme de goût, de design, et de liberté de composition; c'est l'endroit où le savoir-faire rencontre le savoir composer, en créant des solutions toujours nouvelles, caractérisées par une grande épaisseur qualitative et formelle. La capacité de construire un produit fiable et durable, alliée à un réseau de distribution très ramifié et international, ont permis à la SICCC de devenir un point de référence consolidé pour le marché mondial des cuisines. La versatilité et le style la rendent le partenaire sûr pour vous guider dans le choix de votre prochaine cuisine.

SICC

ist Synonym für Geschmack, Design, Kombinationsfreiheit; ist der Ort, an dem das Wissen ums Handwerk das Wissen der Komposition trifft, um immer neue Lösungen zu bilden, von starker qualitativer und formeller Gestaltungskraft. Die Fähigkeit, ein zuverlässiges und dauerhaftes Produkt herzustellen, vereint mit dem flächendeckenden und internationalen Vertriebsnetz, haben aus SICCC einen soliden Anhaltspunkt des internationalen Küchenmarkts gemacht. Vielseitigkeit und Stil machen aus ihr einen sicheren Partner in der Wahl Ihrer nächsten Küche.

SICC

es sinónimo de gusto, diseño, libertad de composición; es el lugar en donde el saber hacer encuentra el saber componer, generando soluciones siempre nuevas, de gran importancia cualitativa y formal. La capacidad de construir un producto fiable y durable, junto con una red de distribución capilar e internacional, han hecho que SICCC sea un punto de referencia consolidado para el mercado mundial de las cocinas. Versatilidad y estilo la hacen un socio seguro en la guía a la elección de vuestra próxima cocina.

SICC

это синоним вкуса, дизайна, свободы компоновки; это место, где соединяются умение делать и умение компоновать, создавая новые высококачественные, точные решения. Способность конструировать надежные, долговечные изделия и широкая международная дистрибьюторская сеть позволили SICCC прочно занять позицию лидера на международном рынке кухонной мебели. Благодаря гибкости и стилю компания становится заслуживающим доверия партнером при выборе будущей кухни.



02 PLUS

Qualità delle materie prime, cura della lavorazione, versatilità di soluzioni compositive e tecniche, solidità costruttiva: sono solo alcuni dei punti di forza delle nostre cucine.

Scopritene gli altri:
lasciatevi ammaliare da una cucina SICC.

Quality raw materials, painstaking processing, versatility of composition and technical solutions, sturdy construction: these are just some of the strengths of our kitchens.
Find out more: let yourselves be seduced by a SICC kitchen.

Qualité des matières premières, phases d'usinage soignées, versatilité de solutions techniques et de composition, construction solide: ce sont seulement certains des atouts de nos cuisines.
Venez en découvrir d'autres : laissez-vous séduire par une cuisine SICC.

Qualität der Rohstoffe, Sorgfalt in der Bearbeitung, Vielseitigkeit der Kombinationen und technischen Lösungen, konstruktive Haltbarkeit: das sind nur einige der Vorteile unserer Küchen.
Entdecken Sie die anderen:
lassen Sie sich von einer SICC Küche bezaubern.

Calidad de las materias primas, cuidado en la elaboración, versatilidad de soluciones de composición y técnicas, solidez de construcción: son solo algunos de los puntos fuertes de nuestras cocinas.
Descubrid los otros: dejaos hechizar por una cocina SICC.

Качество сырья, контролируемый процесс изготовления, разнообразие композиционных и технических решений, конструктивная прочность – это лишь некоторые выигрышные стороны наших кухонных гарнитуров. Узнайте об остальных преимуществах, поддавшись очарованию кухни SICC!

GUIDA ALLA LETTURA

key . légende . Zeichenerklärung . leyenda .
условные обозначения

colori base legno relativi al singolo modello

basic wood colours relating to each individual model
couleurs base bois pour chaque modèle
Holzbasisfarben jedes einzelnen Modells
colores mueble bajo madera relativos a cada modelo
базовые цвета дерева для отдельной модели



scopri tutte le altre finiture disponibili in fondo al catalogo

discover all the other finishes available at the back of the catalogue
découvrez toutes les autres finitions disponibles à l'arrière du catalogue
Die Liste der restlichen Finishes befindet sich am Ende des Katalogs
descubre todos los demás acabados disponibles al final del catálogo
посмотреть другие возможные варианты отделки в конце каталога

flessibilità

SICC offre una gamma di modelli unica per versatilità, infinita per possibilità di abbinamenti, piacevolmente varia per le molteplici declinazioni cromatiche disponibili.

SICC offers a range of models that is unique in its versatility, infinite in the combination possibilities, pleasantly varied in the multitude of colours available.

SICC offre une gamme de modèles unique pour sa versatilité, infinie pour la possibilité de combinaisons, agréablement variées pour les multiples déclinaisons chromatiques disponibles.

SICC bietet ein großes Angebot an Modellen, das einzigartig in der Vielseitigkeit, unendlich in den Kombinationsmöglichkeiten, angenehm abwechslungsreich in den vielfältigen erhaltlichen chromatischen Abstufungen.

SICC ofrece una gama de modelos única por su versatilidad, infinita por sus posibilidades de combinaciones, agradablemente diferente por sus múltiples tonalidades de color disponibles.

Модели кухонных гарнитуров SICC уникальны своей многогранностью, безграничными возможностями комбинаций, богатством и разнообразием цветов.

affidabilità

Elementi strutturali solidi e resistenti, finiture impeccabili. E, naturalmente, legni che provengono solo da zone con obbligo di riforestazione.

Sturdy and durable structural elements, impeccable finishes. And, naturally, woods which originate from areas governed by reforestation laws.

Des éléments structurels solides et résistants, des finitions impeccables. Et, naturellement, des bois provenant seulement de zones où la replantation est obligatoire.

Strukturelle Elemente, die solide und beständig sind, tadellose Finishes. Und, natürlich, Hölzer, die nur aus Zonen mit Verpflichtung der Wiederbeforstung bezogen werden.

Elementos estructurales sólidos y resistentes, acabados impecables. Y, naturalmente, maderas que provienen solo de zonas con obligación de reforestar.

Прочные структурные элементы и безупречная отделка. Все дерево поставляется из областей с обязательным лесонасаждением.

AZIENDA
about us . l'entreprise . Unternehmen . compañía . о компании

QUALITÀ MATERIALI
quality materials . matériaux de qualité . Qualität der Materialien .
calidad de los materiales . качество материалов

MODERNO
modern . moderne . modern . moderno . современный стиль

S 89 6
S 78 8
S 77 10
S 76 14
S 73 16
S 71 18
S 62 20
S 64 22
S 67 24
S 68 26

CLASSICO
classic . classique . klassisch . clásico . классика

S 75 30
S 74 34
S 72 38
S 59 40
S 61 42
S 51 44
S 50 46

PROVENÇAL STYLE

S 79 50
S 80 52
S 81 54
S 82 56
S 88 58

FINITURE PROVENÇAL STYLE 60
provençal style finishes . finitions style provençal . Finishes provençal style .
acabados provençal style . прованс: варианты отделки

MURATURA 62
brickwork . maçonnerie . Mauerwerk . mampostería . каменная кладка

COLORI 64
colours . couleurs . Farben . colores . цвета

S



89
78
77
76
73
71
62
64
67
68

M



MODERNO

modern . moderne . modern . moderno . современный стиль





S 89

5
 / nobilitati tranchè
 / tranché veneered
 / mélaminé tranché
 / Furnier Tranché
 / melamina tranchè
 / ДСП с меламиновым
 покрытием и отделкой
 «транше»

+ 26
 / laccati opachi
 / matt lacquered
 / laqué mat
 / matt lackiert
 / lacados opacos
 / лакированная панель с
 матовой отделкой

noce siena rovere cenere rovere luna rovere terra lava





S 78

→

2
 / polimerico finitura legno
 / wood finish polymer
 / polymère finition bois
 / Polimerisat mit Holzfinish
 / polimérico acabado madera
 / полимер с отделкой деревом

⊕ **4**
 / polimerico finitura satinata
 / satin finish polymer
 / polymère finition satinée
 / Polimerisat mit satiniertem Finish
 / polimérico acabado satinado
 / полимер с матовой отделкой

→

ciliegio noce



S 77





S 77

→

3
 / legni impiallacciati
 / veneered woods
 / bois plaqués
 / Furnierhölzer
 / maderas chapadas
 / Шпон

+ 4
 / polimerico finitura satinata
 / satin finish polymer
 / polymère finition satinée
 / Polimerisat mit satiniertem Finish
 / polimérico acabado satinado
 / полимер с матовой отделкой

+ 6
 / polimerico finitura lucida
 / glossy finish polymer
 / polymère finition brillante
 / Polimerisat mit glänzendem Finish
 / polimérico acabado brillante
 / полимер с глянцевой отделкой

→

7
 / polimerico finitura legno
 / wood finish polymer
 / polymère finition bois
 / Polimerisat mit Holzfinish
 / polimérico acabado madera
 / полимер с отделкой деревом

+ 3
 / polimerico finitura stinata dogato
 / slatted satin finish polymer
 / polymère finition satinée à lattes
 / Polimerisat satiniertes Finish mit Bretteffekt
 / polimérico acabado satinado modular
 / Полимер с сатинированной отделкой и рельефом

+ 26
 / MDF laccato opaco o lucido
 / matt or glossy lacquered MDF
 / MDF laqué mat ou brillant
 / MDF matt oder glänzend lackiert
 / MDF lacado opaco o brillante
 / лакированная панель МДФ с матовой или глянцевой отделкой

→

rovere chiaro rovere moro noce canaletto



→

rovere moro rovere sbiancato rovere grigio ciliegio noce ebano lucido ciliegio lucido





S 76

4
 / legni massello_impiallacciati
 / solid_veneered woods
 / bois massifs_plaqués
 / Massivholz_Furnier
 / maderas macizas_chapadas
 / Массив и шпон

+ 26
 / MDF laccato opaco
 / matt lacquered MDF
 / MDF laqué mat
 / MDF matt lackiert
 / MDF lacado opaco
 / лакированная панель МДФ с матовой отделкой

ciliegio rovere grigio rovere gessato rovere tortora





S 73

3

/ legni impiallacciati
/ veneered woods
/ bois plaqués
/ Furnierhölzer
/ maderas chapadas
/ Шпон

+ 3

/ polimerico finitura satinata dogato
/ slatted satin finish polymer
/ polymère finition satinée à lattes
/ Polimerisat satiniertes Finish mit Bretteffekt
/ polimérico acabado satinado modular
/ Полимер с сатиновой отделкой и рельефом

2

/ polimerico finitura legno
/ wood finish polymer
/ polymère finition bois
/ Polimerisat mit Holzfinish
/ polimérico acabado madera
/ полимер с отделкой деревом

+ 26

/ MDF laccato opaco o lucido
/ matt or glossy lacquered MDF
/ MDF laqué mat ou brillant
/ MDF matt oder glänzend lackiert
/ MDF lacado opaco o brillante
/ Лакированная панель МДФ с матовой или глянцевой отделкой

rovere chiaro rovere moro noce canaletto



ebano lucido ciliegio lucido





S 71

- | | |
|---|--|
| <p>8
 / vetri lisci o dogati con telaio alluminio
 / smooth or slatted glazing with aluminium frame
 / vitres lisses ou à lattes avec cadre en aluminium
 / Glas glatt oder mit Bretteffekt in Aluminiumrahmen
 / cristales lisos o modulares con armazón de aluminio
 / стекла гладкие или рифленые с рамой из алюминия</p> | <p>1
 / vetro nero liscio o dogato con telaio alluminio nero
 / smooth or slatted black glazing with black aluminium frame
 / vitre lisse ou à lattes noire avec cadre en aluminium noir
 / Schwarzes Glas glatt oder mit Bretteffekt in schwarzem Aluminiumrahmen
 / cristal negro liso o modular con armazón de aluminio negro
 / стекло черное гладкое или рифленое с черной рамой из алюминия</p> |
|---|--|





S 62

3

/ polimerico finitura legno
 / wood finish polymer
 / polymère finition bois
 / Polimerisat mit Holzfinish
 / polimérico acabado madera
 / полимер с отделкой деревом

+

6

/ polimerico finitura lucida
 / glossy finish polymer
 / polymère finition brillante
 / Polimerisat mit glänzendem Finish
 / polimérico acabado brillante
 / полимер с глянцевой отделкой

rovere moro rovere sbiancato rovere grigio

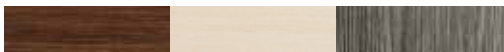



S 64

3
 / legni impiallacciati
 / veneered woods
 / bois plaqués
 / Furnierhölzer
 / maderas chapadas
 / Шпон

+ 26
 / MDF laccato opaco o lucido
 / matt or glossy lacquered MDF
 / MDF laqué mat ou brillant
 / MDF matt oder glänzend lackiert
 / MDF lacado opaco o brillante
 / Лакированная панель МДФ
 с матовой или глянцевой отделкой

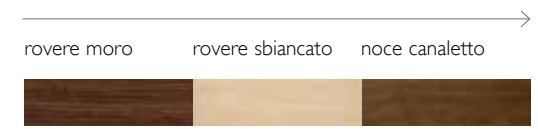



S 67

6

/ nobilitati matrix
 / matrix veneered
 / mélaminé matrix
 / Fumier Matrix
 / melaminas matrix
 / ДСП с меламиновым покрытием с отделкой «матрикс»

bianco

grigio

marrone

rosso

verde

zebrano

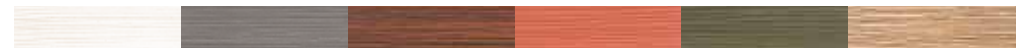



S 68

3
 / nobilitati frassinati finitura legno
 / wood finish ash-wood effect veneered
 / mélaminé effet frêne finition bois
 / Furnier Esche mit Holzfinish
 / melaminas efecto fresno acabado madera
 / ДСП с меламиновым покрытием под ясень, отделка деревом

3
 / nobilitati frassinati
 / ash-wood effect veneered
 / mélaminé effet frêne
 / Furnier Esche
 / melaminas efecto fresno
 / ДСП с меламиновым покрытием под ясень

ciliegio rovere moro rovere sbiancato



bianco bordeaux grigio



S



75
74
72
59
61
51
50

C



CLASSICO

classic . classique . klassisch . clásico . классика



S 75





S 75

1
 / legno massello
 / solid wood
 / bois massif
 / Massivholz
 / madera maciza
 / Массив

noce



1
 / legno massello laccato opaco con scopertura argento
 / matt lacquered solid wood with silver stripping
 / bois massif laqué mat avec décapage argent
 / Massivholz matt lackiert mit Silberfreilegungen
 / madera maciza lacada opaca con partes descubiertas plata
 / Массив, покрытый матовым лаком, с потертостями (серебро)

bianco



S 74





S 74

15

/ legni massello laccati opachi a poro aperto
 / open pore matt lacquered solid woods
 / bois massifs laqués mats à pore ouvert
 / Massivhölzer offenporig matt lackiert
 / maderas macizas lacadas opacas con poro abierto
 / Массив, покрытый матовым лаком, с открытыми порами

bianco panna avorio sabbia beige grigio argilla marrone caffè antracite nero bordeaux lilla melanzana porpora verde oliva blu





S 72

1

/ polimerico frassinato opaco
 / matt ash-wood effect polymer
 / polymère effet frêne mat
 / Polimerisat mit mattem Eschenfumiereffekt
 / polimérico efecto fresno opaco
 / полимер с ясенем с матовой отделкой



bianco



1

/ polimerico lucido
 / glossy polymer
 / polymère brillant
 / Polimerisat glänzend
 / polimérico brillante
 / полимер с глянцевой отделкой



bianco



+ 26

/ polimerico frassinato laccato opaco
 / matt lacquered ash-wood effect polymer
 / polymère effet frêne laqué mat
 / Polimerisat mit lackiertem mattem
 Eschenfumiereffekt
 / polimérico efecto fresno lacado opaco
 / полимер с ясенем лакированный,
 с матовой отделкой





S 59



2
 / legni massello_impiallacciati
 / solid_veneered woods
 / bois massifs_plaqués
 / Massivholz_Furnier
 / maderas macizas_chapadas
 / Массив и шпон



castagno noce





S 61

3

/ legni massello verniciati opachi all'anilina
 / matt aniline painted solid woods
 / bois massifs peints mats à l'aniline
 / Massivhölzer matt anilinelackiert
 / maderas macizas barnizadas opacas con anilina
 / Массив крашенный матовый (анилиновая краска)

avorio verde celeste





S 51

- 1
 / legno massello_impiallacciato, laccato decapè con patinatura verde nel perimetro della bugna
 / solid_veneered wood, stripped lacquered with green patina coating along the edge of the central panel
 / bois massif_plaqué, laqué décapé avec patine verte le long du périmètre du panneau central
 / Massivholz_Furnier Decapè-lackiert mit grünem Patina auf gesamtem Umfang des Aufsatzes
 / madera maciza_chapada, lacada decapé con pátina verde en el perímetro de la almohadilla
 / Массив и шпон, покрытые лаком, с отделкой «декапе» и зеленой патиной по периметру филенки

→
 avorio





S 50



1
 / legno massello
 / solid wood
 / bois massif
 / Massivholz
 / maderá maciza
 / Массив



noce



S

Languedoc. s79

Provence. s80

Perigord. s81

Laurac. s82

Sully. s88



Provencal
STYLE



s79. Languedoc



4

/ tinte legno
/ wood colours
/ couleurs bois
/ Holzfarben
/ colores de la
Madera
/ Оттенки
дерева

12

/ laccati opachi
/ matt lacquered
/ laqué mat
/ lackiert
/ lacados opacos
/ лакированная
панель с
матовой
отделкой

12

/ laccati con patina
/ lacquered with patina coating
/ laqué avec patine
/ lackiert mit Patina
/ lacados con pátina
/ лакированная панель с
патиной

12

/ laccati con scoperture
/ lacquered with stripping
/ laqué avec décapage
/ lackiert mit Freilegungen
/ lacados con partes
descubiertas
/ лакированная панель с
потертостями



s80. Provence



- | | | | |
|---|--|--|---|
| <p>4
/ tinte legno
/ wood colours
/ couleurs bois
/ Holzfarben
/ colores de la Madera
/ Оттенки дерева</p> | <p>12
/ laccati opachi
/ matt lacquered
/ laqué mat
/ matt lackiert
/ lacados opacos
/ лакированная панель с матовой отделкой</p> | <p>12
/ laccati con patina
/ lacquered with patina coating
/ laqué avec patine
/ lackiert mit Patina
/ lacados con pátina
/ лакированная панель с патиной</p> | <p>12
/ laccati con scoperture
/ lacquered with stripping
/ laqué avec décapage
/ lackiert mit Freilegungen
/ lacados con partes descubiertas
/ лакированная панель с потертостями</p> |
|---|--|--|---|





s81. Perigord



4

/ tinte legno
/ wood colours
/ couleurs bois
/ Holzfarben
/ colores de la
Madera
/ Оттенки
дерева

12

/ laccati opachi
/ matt lacquered
/ laqué mat
/ matt lackiert
/ lacados opacos
/ лакированная панель
с матовой отделкой

12

/ laccati con patina
/ lacquered with patina
coating
/ laqué avec patine
/ lackiert mit Patina
/ lacados con pátina
/ лакированная панель
с патиной

12

/ laccati con scoperture
/ lacquered with
stripping
/ laqué avec décapage
/ lackiert mit
Freilegungen
/ lacados con partes
descubiertas
/ лакированная панель
с потертостями



s82. Laurac



4

/ tinte legno
/ wood colours
/ couleurs bois
/ Holzfarben
/ colores de la Madera
/ Оттенки дерева

12

/ laccati opachi
/ matt lacquered
/ laqué mat
/ matt lackiert
/ lacados opacos
/ лакированная панель с матовой отделкой

12

/ laccati con patina
/ lacquered with patina coating
/ laqué avec patine
/ lackiert mit Patina
/ lacados con pátina
/ лакированная панель с патиной

12

/ laccati con scoperture
/ lacquered with stripping
/ laqué avec décapage
/ lackiert mit Freilegungen
/ lacados con partes descubiertas
/ лакированная панель с потертостями





s88. Sully



4

/ tinte legno
/ wood colours
/ couleurs bois
/ Holzfarben
/ colores de la Madera
/ Оттенки дерева

12

/ laccati opachi
/ matt lacquered
/ laqué mat
/ matt lackiert
/ lacados opacos
/ лакированная панель с матовой отделкой

12

/ laccati con patina
/ lacquered with patina coating
/ laqué avec patine
/ lackiert mit Patina
/ lacados con pátina
/ лакированная панель с патиной

12

/ laccati con scoperture
/ lacquered with stripping
/ laqué avec décapage
/ lackiert mit Freilegungen
/ lacados con partes descubiertas
/ лакированная панель с потертостями

Ante Lavorazioni
Door Processing . Portes Finitions . Bearbeitungsarten der Türen . Puertas Elaboración .
Отделка фасадов



Anticatura.
L'usura tipica generata dagli agenti temporali e naturali viene ricreata attraverso l'azione circoscritta e controllata di strumenti di incisione, puntellatura e martellatura.

Distressed finish.
The typical wear created by the weather and by natural agents is recreated through the accurate and controlled action of engraving, abrasive blasting and hammering tools.

Patina.
Applicazione di colore a contrasto su zone perimetrali parzialmente rimosso attraverso tamponatura.

Patina coating.
Application of contrasting colour on perimeter zones which is partially removed through buffing.

Scopertura.
Piccole porzioni di superficie vengono abrase, in modo da portare alla luce il legno, conferendogli un aspetto consunto dal tempo.

Stripping.
Small portions of the surface are abraded so as to reveal the wood underneath, giving it a time-worn appearance.

Vieillessement.
L'usure typique générée par les agents temporels et naturels est recréée par l'action précise et contrôlée d'outils pour l'entaille, de sablage et le martelage.

Antikisierung.
Die zeitbedingte und natürliche typische Abnutzung wird vorausgenommen mit einer kontrollierten und genauen Aktion von Gravur, Stich- und Hammerwerkzeugen.

Patine.
Application de couleur en contraste sur des zones périmétrales partiellement enlevée par tamponnage.

Patina.
Auftrag einer kontrastierenden Farbe auf den Randzonen, der teilweise mittels Abtupfen wieder abgetragen wird.

Décapage.
De petites portions de la surface sont abrasées, pour exposer le bois, en lui donnant un aspect usé par le temps.

Freilegung.
Kleine Teile der Oberfläche werden abgetragen, damit die unterliegende Holzschicht ans Licht gebracht wird, und so ein antikes Aussehen garantiert wird.

Envejecimiento.
El típico desgaste generado por los agentes temporales y naturales es recreado mediante la acción circunscrita y controlada de instrumentos para grabar, punzar y martillar.

Старение.
Стандартный износ временем и естественными причинами воссоздается посредством тщательно дозированного нанесения насекомых, точек и ковки.

Pátina.
Aplicación de color en contraste en las zonas externas en parte eliminado con un paño.

Патина
Нанесение по периметру контрастного цвета, часть которого удаляется тампоном.

Partes descubiertas.
Pequeñas partes de superficie se abrasan, con el fin de sacar a la luz la madera, dándole un aspecto desgastado por el tiempo.

Потертость.
Небольшие части поверхностей затираются до дерева, что создает эффект износа временем.

ANTE IN ROVERE MASSELLO_IMPIALLACCIATO
SOLID/VENEERED OAK-WOOD DOORS . PORTES EN ANTE IN CHÊNE MASSIF/PLAQUÉ .
TÜR AUS EICHENMASSIVHOLZ/FURNIER . PUERTA EN ROBLE MACIZO/CHAPADO .
ФАСАДЫ ИЗ МАССИВА ДУБА/ШПОНА



Tinte Legno
Wood colours . Couleurs bois . Holzfarben . Colores de la Madera . Оттенки дерева



rovere naturale opaco rovere chiaro rovere scuro rovere sbiancato

Laccati
Lacquered . Laqués . Lackiert . Lacados . лакированные



cacao bianco melanzana grigio antracite



azzurro bordeaux avorio sabbia



giallo lavanda cappuccino nero

Patine Laccati
Lacquered Patina coatings . Patines Laquées . Lackpatinas . Pátinas Lacados .
Патина лакированных поверхностей



terracotta neve blu lavanda sughero



alloro celeste vaniglia



oro argento

Solo su fondo bianco o nero
Only on black or white background
Seulement sur fond noir ou blanc
Nur auf weißem oder schwarzem Grund
Sólo sobre fondo blanco o negro
Только на белом или черном фоне

03 MURATURA

Oltre 1.500 articoli in muratura in abbinamento alle linee Classico e Provençal Style.

Over 1,500 brickwork items teamed with the Classic and Provençal Style lines.

Plus que 1 500 articles en maçonnerie en combinaison avec les lignes Classique et Style Provençal.

Über 1500 Produkte aus Mauerwerk, passend zu den Linien Klassisch und Provençal Style.

Más de 1.500 artículos en mampostería para combinar con las líneas Classico e Provençal Style.

Более 1500 изделий с каменной кладкой, сочетающихся с линиями «Классика» и «Прованс»

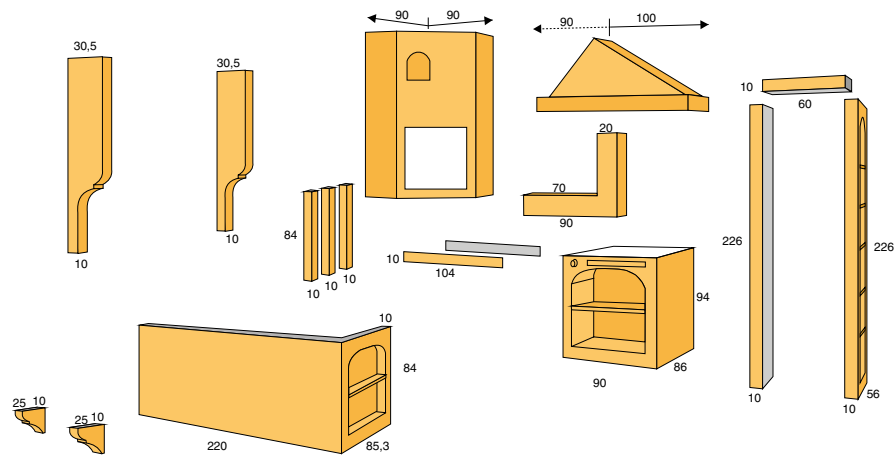

FINITURE MURO

WALL FINISHES . FINITIONS MUR . FINISHS DER MAUERELEMENTE . ACABADOS MAMPOSTERÍA . ОТДЕЛКА КАМЕННОЙ КЛАДКИ

Colori Etruria / Colori Etruria lux

Etruria colours / Etruria lux colours . Couleurs Etruria / Couleurs Etruria lux . Farben Etruria / Farben Etruria lux . Colores Etruria / Colores Etruria lux . Цвета Etruria / Цвета Etruria lux



Colori Boemia / Colori Boemia lux

Boemia colours / Boemia lux colours . Couleurs Boemia / Couleurs Boemia lux . Farben Boemia / Farben Boemia lux . Colores Boemia / Colores Boemia lux . Цвета Boemia / Цвета Boemia lux



Colori Provenza

Provenza colours . Couleurs Provenza . Farben Provenza . Colores Provenza . Цвета Provenza



Colori Acquerello

Acquerello colours . Couleurs Acquerello . Farben Acquerello . Colores Acquerello . Цвета Acquerello

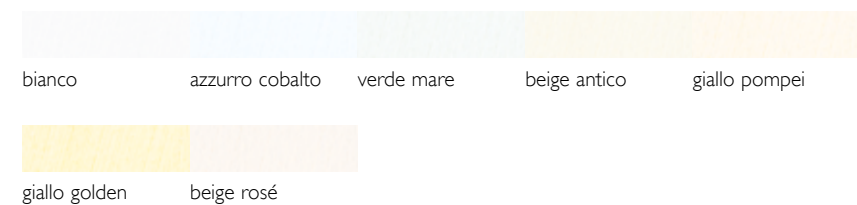

04 | COLORI



Polimerico finitura lucida .

Glossy finish polymer . Polymère finition brillante . Polymerisat mit glänzendem Finish .

Polimérico acabado brillante . Полимер с глянцевой отделкой

S 77 . S 62



bianco

mandorla

rosso pompeii

bordeaux



caffè

nero

Polimerico finitura satinata .

Satin finish polymer . Polymère finition satinée . Polymerisat mit satiniertem Finish .

Polimérico acabado satinado . Полимер с сатирированной отделкой

S 78 . S 77



argilla

bianco

dark beige

rosso pompeii

Polimerico dogato .

Slatted polymer . Polymère à lattes . Polymerisat mit Bretteffekt . Polimérico modular .

Полимер с реечной отделкой

S 77 . S 73

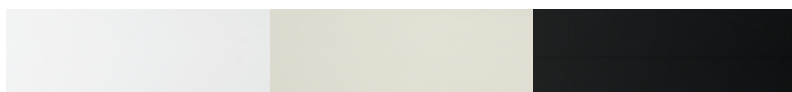

bianco

corda

nero

Laccati . Lacquered . Laqués . Lackiert . Lacados . лакированные

S 89 . S 77 . S 76 . S 73 . S 72 . S 64



bianco

bianco caldo

panna

champagne



avorio

mandorla

dark beige

sabbia



terra

beige grigio

argilla

marrone caffè



dark

antracite

nero

giallo sabbia



giallo melone

rosso pompeii

bordeaux

lilla



melanzana

porpora

pompelmo

verde oliva



blu

mirtillo



sicc
idee chiare
in cucina

SICC spa
60030 Monsano.An.Italy
Via Toscana, 32
tel +39 0731 21881
fax +39 0731 21888

www.sicccucine.com